



**ALI RIZA USTA
TANKER**

VEHICLE REPAIR AND MAINTENANCE MANUAL





**ALI RIZA USTA
TANKER**

PROMOTION

We established our company in Karatay Industry as Ali Rıza Usta in 1975. Our production started with the production of on-vehicle fuel tanks and various tanks. As a result of continuous and stable work, our company has grown rapidly. Our company, which attaches importance to quality and aesthetics, was founded in 1994 by Ali Rıza Usta.

He received the title of Tanker Industry and Trade Limited Company. While our on-board tank production is 10 per month, this number has reached 70 per month.

Our company, which closely follows technological innovations, moved to its factory in Ankara-Adana ring road in 1996, thanks to its quality and continuous stability.

In addition to classical tanker production, our company manufactures silobas, tipper, military service vehicle, trailer and aluminum tanker productions with ISO quality certificate and assurance.

In addition to the domestic market, our company, which has opened to foreign markets, has managed to produce in Europe, Asia and the Middle East countries.

PRODUCTION RANGE

Our production range is from 18 m³ to 60 m³ for tankers, from 22 m³ to 54 m³ for silobase, and we are trying to renew our designs every day and aim to expand our product tree.



ALI RIZA USTA TANKER

INDEX

- 1- Suspensions**
- 2- Braking**
- 3- Wheel Bearing Lubrication and Adjustment**
- 4- Electrical System**
- 5- Rim and Wheel Inspection and Maintenance**
- 6- Kingpin**
- 7- Rear Impact Guard**

1) SUSPENSIONS

1.1 LEAF-SPRING SUSPENSIONS

Check the torque of all suspension bolts after initial break-in period on the road and thereafter at regular intervals not to exceed 35,000 kilometers. Follow the torquing recommendations of the suspension manufacturer. If they are not available, use the following table of torque recommendations for clean dry threads. The use of lubricants will apply more tensile force for the same torque. If lubricants are used, decrease torque approximately 30%

1.1.1 Check axle alignment. Also check after replacing any suspension parts or if the trailer does not track behind the tractor or if unusual tire wear is noted. Move trailer forward onto a flat level surface. Inflate tires to rated pressure and check the kingpin to the front axle end dimensions. They must be within plus or minus "0" to expect maximum tire mileage. The front axle to the rear axle end dimensions must be within plus or minus "0" to expect maximum tire mileage.



ALI RIZA USTA TANKER

1.1.2 Check all bushings for wear. Replace any worn bushings and re-torque the mounting bolts and nuts to the manufacturer's recommended specifications or refer to the table at the end of this section.

1.1.3 Check the equalizer for obstructions that can limit movement and cause damage or limit load transfer between axles.

1.1.4 Check spring wear pads in the hangers and equalizers. Worn pads should be replaced before the springs damage the hanger walls. Wear will allow axle shift and cause misalignment and premature tire wear.

1.1.5 Check springs for broken or missing leaf sections, misalignment or wear. Replace broken springs. DO NOT weld on any spring. DO NOT replace individual leaves and DO NOT operate with broken spring leaves.

1.1.6 Check frame, hangers and equalizer for cracks, breaks or broken welds. Repair or replace according to the suspension manufacturer's specifications. All cracks should be welded and covered by reinforcing plates to preserve their integrity and prevent failure of the repair.

1.2 AIR SPRING SUSPENSIONS

The air-spring suspension height is controlled by height control valves that maintain a constant trailer height by pressurizing or exhausting air in the air springs as needed to support the load being carried.

If an air-spring failure occurs on one side, it is recommended to completely deflate the suspension and temporarily operate on the air springs' internal rubber bumpers to allow your trailer to be moved to a shop for repairs.

To deflate or cut off the air pressure to the damaged air spring, disconnect the height control valve actuating levers from their link assemblies and rotate to the vertical down position.

1.2.1 Check axle alignment. Also check alignment after replacing any suspension parts or if the trailer does not track behind the tractor or if unusual tire wear is noted. Move the trailer forward to a flat, level surface. Inflate the tires to the rated pressure and check the kingpin to the front axle end dimensions. The dimensions must be within plus or minus "0" to expect maximum tire mileage. Adjust using the suspension manufacturers procedures as needed. Check the front to rear axle end dimensions. These must be within plus or minus "0" to expect maximum tire mileage.



ALI RIZA USTA TANKER

1.2.2 Check all bushings for wear. Replace any worn bushings and re-torque the mounting bolts and nuts to the manufacturers recommended specifications. Worn component parts or loose U-bolts can allow the vehicle to roll or sway.

1.2.3 Check the airlines for leaks and repair or replace any parts, which cause the suspension lines to leak air.

1.2.4 Check the air bags for wear, leaks, deterioration, cracks, folded or misaligned sections. Replace bags that have the internal reinforcing fabric showing. Clearance around the air bags should not be less than 45 mm when the bags are inflated. If there is less clearance check for any deterioration or loose or misaligned parts that are the cause.

1.2.5 Check the hangers, trailing arms, axle seats and frame for cracks, breaks, deformed surfaces or broken welds. Repair or replace according to the manufacturer's recommendations.

1"	14 UNC	350-375 lb-ft
7/8"	14 UNF	275-300 lb-ft
5/8"	18 UNF	75-90 lb-ft
5/8"	18 UNF	125-155 lb-ft (step bolts)
1/2"		45-50 lb-ft

1) BRAKING

Proper operation of the brake systems requires a firm seal between the air brake couplers. Inspect the couplers for seal damage and cracked housings. Some couplers are equipped with filters. These filters must be cleaned at regular intervals to prevent malfunction of the brake systems. Inspect the air hoses for cracking and for frayed connections. Be sure air hoses are not rubbing on any metal surface or each other. Replace or repair damaged components.

Keep the air system clean. All air tanks should be drained daily to remove moisture and other contaminants.



ALI RIZA USTA TANKER

If you use Teflon tape or other thread sealers to seal threaded connections in your air lines, be careful not to allow pieces of the sealer to enter the air system. It can clog passages into the valves and cause them to malfunction.

Keep the air system tight. The air system cannot be charged properly if there are leaks in reservoirs, lines, hoses, or valves. Always check the tractor pressure gauge for unusual drops or extended buildup times.

Run the tractor engine until the air brake system pressure gauge shows at least 105 psi. Listen for air leaks. With the engine off, check the gauge reading with no brakes applied. The gauge reading loss should not exceed three psi in one minute.

WARNING!

Trailer axles are equipped with spring brake chambers. These operate the emergency and the parking brakes. **DO NOT** deactivate these chambers and **DO NOT** attempt to disassemble or open a spring brake chamber. An internal spring is in the chamber under high compression. It is extremely dangerous and could cause serious injury and/or death if opened.

2.1 PARKING BRAKE

All axles (except some converter dolly axles) are equipped with air/spring actuators. Each actuator is separated into two units. The base unit applies the service brakes. The top unit contains a coil spring that must be compressed by air within the chamber to release the parking brakes. Loss of air pressure in the supply line to the brake chamber will automatically apply parking and/or emergency braking. In case of a service brake system air failure, when the spring brakes are applied in an emergency stop, a spring brake air reservoir retains enough stored air to release the spring brakes at least once by means of the tractor parking brake control.

In the absence of air pressure, a manual release is provided to allow release of the spring brake (see following instructions).

To manually release parking brake actuators:



ALI RIZA USTA TANKER

1. Always position wheel chocks at both front and rear of tires before manually releasing parking brakes.
2. A parking brake release tool may be stored in a pocket on the side of the brake chamber. (See photo.)

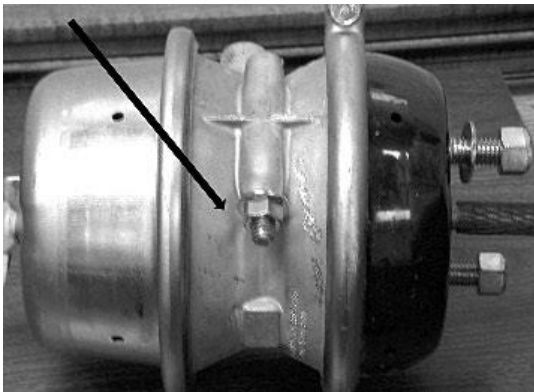

3. Insert the detachable release bolt through hole in head. Turn the release bolt clockwise until it stops and locks, then pull the release bolt out as far as possible, and run the nut down, holding the bolt in place.

Using a hand wrench, turn the release bolt nut clockwise until the bolt extends about three inches. Make sure the release bolt is locked properly in the piston.

The parking brake coil spring is now caged.

3) WHEEL BEARING LUBRICATION AND ADJUSTMENT

The wheel end bearings are lubricated in one of two ways. Use either with oil or semi-fluid grease. Oil lubricated bearings can be identified by looking at the hubcap ends which will have a clear face and shows the oil level in the hub. Synthetic grease hubcaps are solid, without a clear end face and do not allow checking the lubrication level by sight.

3.1 Check hubcap face, gasket and hub end for oil leakage before every trip. Check inner wheel and seal area for indications of oil leaking into the brakes, drum or wheel. Add oil if the level is low, but **DO NOT** operate the trailer if oil is present on the wheel end, until repairs have been made.

3.2 Check for grease on the hubcap, vent, gasket, wheel or inner brake mechanism, if equipped with synthetic grease before every trip. This is more difficult to check than oil.



ALI RIZA USTA TANKER

The grease will mix with road dust and form a paste like coating on the wheel end parts when it leaks.

DANGER!

Undetected grease loss can lead to damaged bearings or wheel end failure.

3.3 Wheel ends lubricated by synthetic grease require inspections annually, or at no more than 160,000 kilometers intervals. This inspection must be done with the hubcap and outer bearing removed to determine the grease level inside of the hub. Refer to the lubrication supplier's recommendations.

4) ELECTRICAL SYSTEM

The electrical system on every trailer meets or exceeds all federal and state requirements in effect at the time of manufacture. Wherever required by law, lamps and reflectors are marked by the manufacturer to indicate the appropriate specification with which each complies.

For optimum performance and long life from the trailer's lamps and wiring, follow this inspection procedure.

Clean all reflective tape or devices and lamps. See that all lamps burn properly. Replace all burned-out lamps and broken or missing reflective devices. Factory- approved replacement parts should be used, and replacement bulbs or lamps of equal candlepower should be used for safety.

WARNING!

TRAILER IS EQUIPPED WITH ANTILOCK BRAKE SYSTEM (ABS). NO. 7 (BLUE) CIRCUIT IS RESERVED FOR CONTINUOUS POWER SUPPLY TO ABS. FOR MOST EFFECTIVE ABS OPERATION, TOWING VEHICLE MUST SUPPLY MINIMUM OF 10 AMPS AT 12.5 VOLTS TO NO. 4 (RED) & NO. 7 (BLUE) CIRCUITS.



ALI RIZA USTA TANKER

PIN	COLOR	CIRCUIT
1	WHITE	GROUND RETURN TO TOWING VEHICLE
2	BLACK	CLEARANCE, SIDE MARKER & ID LAMPS
3	YELLOW	LEFT TURN SIGNAL & HAZARD LAMPS
4	RED	STOP LAMPS & ABS POWER
5	GREEN	RIGHT TURN SIGNAL & HAZARD LAMPS
6	BROWN	TAIL, LICENSE, CLEARANCE & SIDE MARKER LAMPS
7	BLUE	ABS CONTINUOUS SHARED POWER



**J560
SOCKET**

FAILURE TO HEED THIS WARNING CAN RESULT IN PROPERTY DAMAGE, SERIOUS INJURY OR DEATH

Wiring Diagram

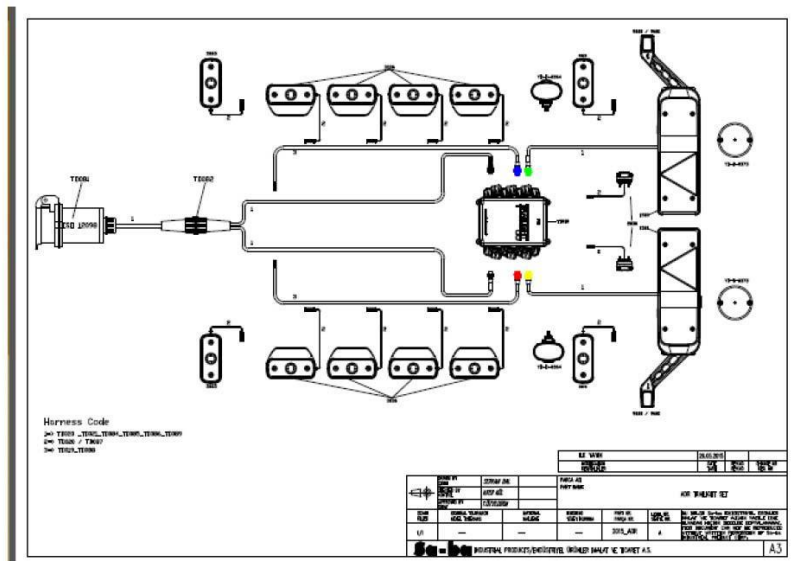

5) RIM AND WHEEL INSPECTION AND MAINTENANCE

5.1 Check all metal surfaces thoroughly, including area between duals and on inboard side of wheel.

Watch for:

- Excessive rust or corrosion buildup
- Cracks



ALI RIZA USTA TANKER

- Bent flanges, resulting from road obstructions
- Deep rim tool marks on rings or in gutter areas
- Loose, missing or damaged nuts or clamps
- Bent or stripped studs
- Damaged or missing rim drive plates
- Mismatched rim parts

5.2 Remove damaged rims or wheels.

5.3 Mark damaged or hazardous areas so that part will be removed from service.

DANGER!

Excessively corroded or cracked rims or rings can be dangerous. Deflate tires prior to the removal of rims or wheels from vehicle.

5.4 Replace damaged parts. Insure that replacements are made with the proper sizes and types of rim wheels.

DANGER!

Be sure that replacements are made with the proper sizes and types of rim wheels.

5.5 Inflate tires only to recommended air pressures.

6) KINGPIN

Inspect the kingpin on the trailer at regular intervals to be sure that it has not suffered damage or undue wear. Although the kingpin is made of hardened forged steel, it is still subject to wear and can be chipped or broken with abuse. Always check the bottom locking flange of the kingpin to determine its condition.



ALI RIZA USTA TANKER

Before coupling the trailer to its tractor be certain that the tractor fifth wheel is properly lubricated and the fifth wheel jaws are open to receive the kingpin.

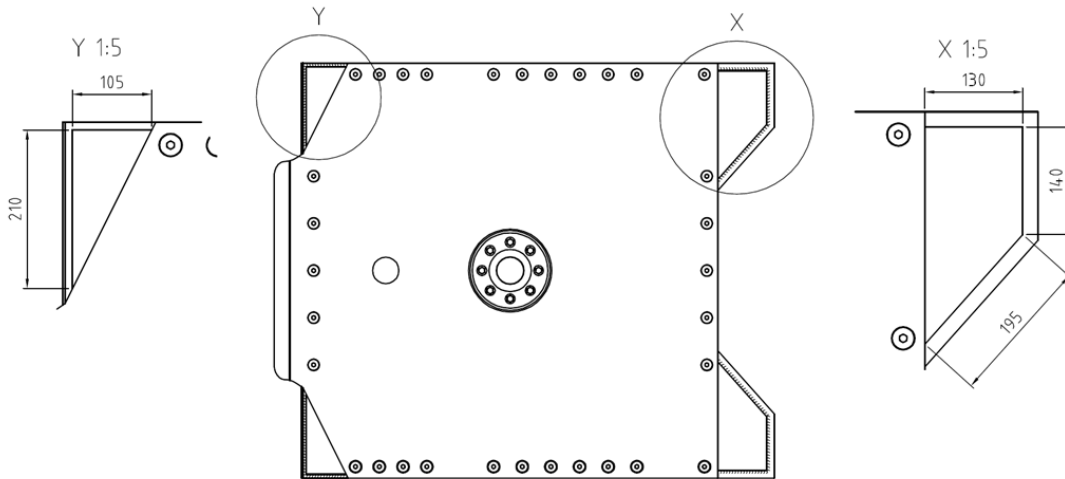

7) REAR IMPACT GUARD

United Nations Economic Commission for Europe (UNECE) Regulations for rear impact guards require the proper maintenance and repair of trailer guards. Trailer guards are subjected to impacts and stress in docking and loading operations. These impacts, as well as the stresses applied by the use of dock restraint equipment, if excessive, can damage any rear guard. A damaged guard may not satisfy the performance requirements now mandated by UNECE and may not be as strong as originally designed and manufactured by ALI RIZA USTA TANKER. ALI RIZA USTA TANKER cannot be responsible for a guard that has been damaged, or for one that is not repaired in accordance with ALI RIZA USTA TANKER design and manufacturing specifications.

Broken welds, bent components, missing or loose fasteners, excessive corrosion or other damage to any trailer guard will likely affect its performance in the event of a rear-end collision. For these reasons, detailed guard inspection, service and repair records should be maintained on all guards for your protection. Repairs must be made in accordance with the guard's original design specifications.

8. BODY AND CHASSIS



ALI RIZA USTA TANKER

The hull and chassis are the primary supporting structures that make up the tanker. Structural parts must be long-lasting and undamaged by using the right design and the right equipment.

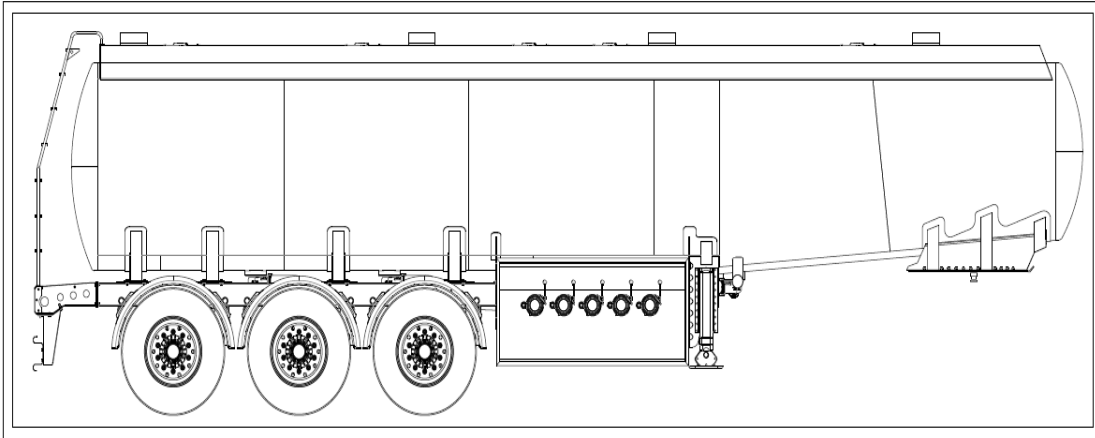

8.1 CHASSIS

It should be noted that there are no damages and cuts on the chassis, the welds are done properly, the bolts are tightened completely and with the correct torque value. The bolt used in the chassis is M16.

It should be noted that M16 Bolt Torque Value is 170 Nm.

- It should be noted that bolts are loose and welding areas of welds are undamaged.

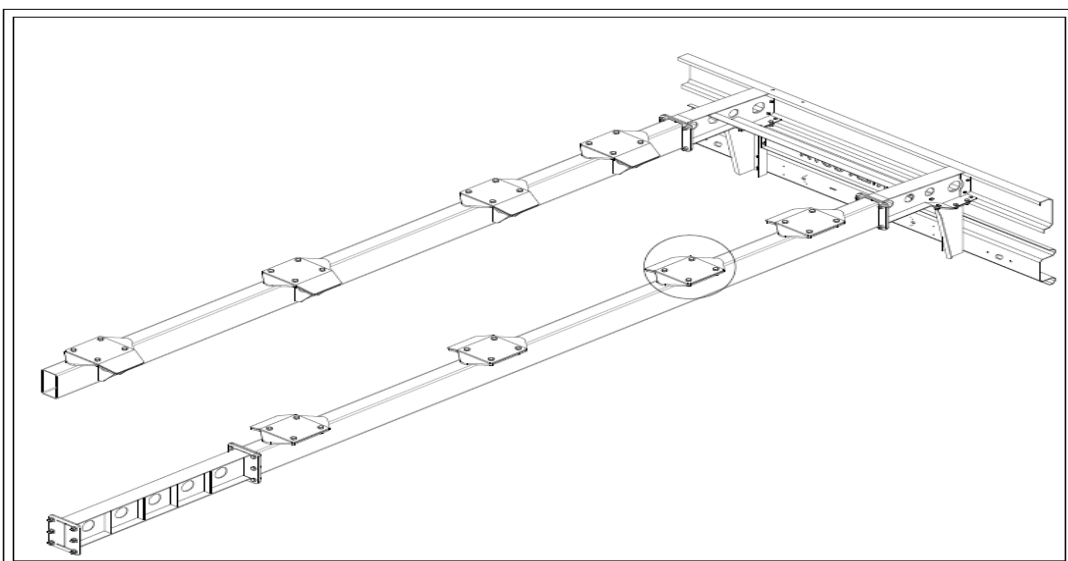



**ALI RIZA USTA
TANKER**

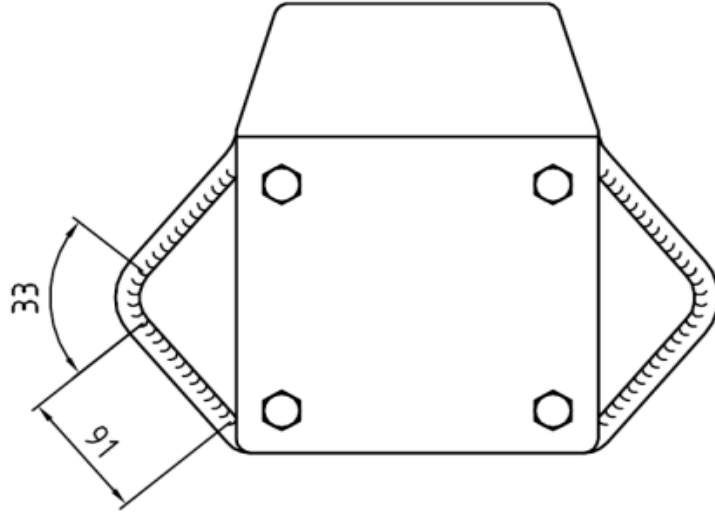

In order to prevent the bolts from getting load during braking on the chassis connection table, support wedges are welded in front and behind the connection plates. In this way, damage to the bolts is prevented.

9. IDENTITY

It is the label with the chassis number of each vehicle produced.

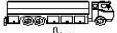
 ALİ RIZA USTA TANKER SAN.TİC.LTD.ŞTİ.	ALİ RIZA USTA TANKER SAN.T İC.LTD.ŞTİ. Büyük kayacık O.S.B Mahallesi 101.Cd. no:18/1 Selçuklu / KONYA/ TÜRKİYE
Vehicle Type Approval Number	e*6*2007/46*0298*00
Vehicle identification Number	
Technically Permissible Maximum Laden Mass	35.000 Kg
Technically Permissible Max.Laden Mass on Coupling Device	0-11.000 Kg
Technically Permissible Max.Laden Mass on 1 st Axle	1-8.000 Kg
Technically Permissible Max.Laden Mass on 2 st Axle	2-8.000 Kg
Technically Permissible Max.Laden Mass on 3 st Axle	3-8.000 Kg
Technically Permissible Max.Laden Mass on Group of Axle	T-24.000 Kg